

POWERTRUSS BRACE - LATERAL BRACING FRAME INSTALLATION

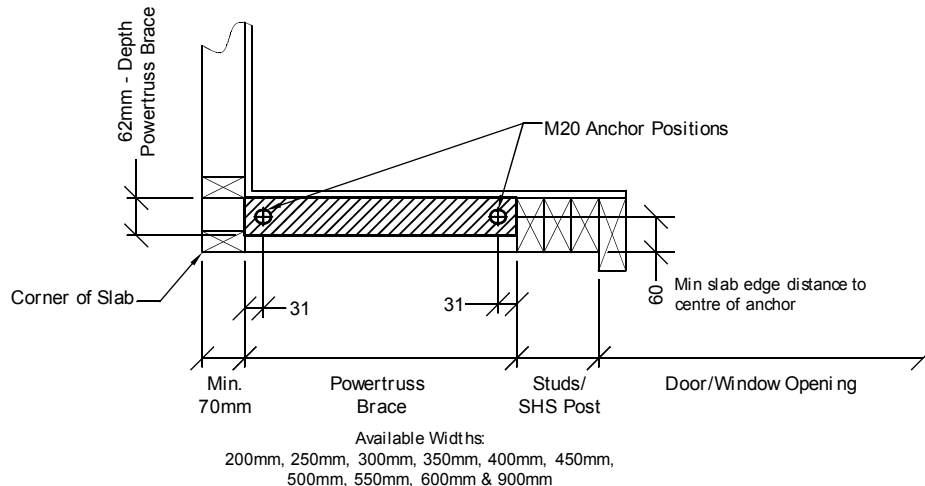

Minimum allowable distance = 70mm from corner of slab to start of Powertruss Frame

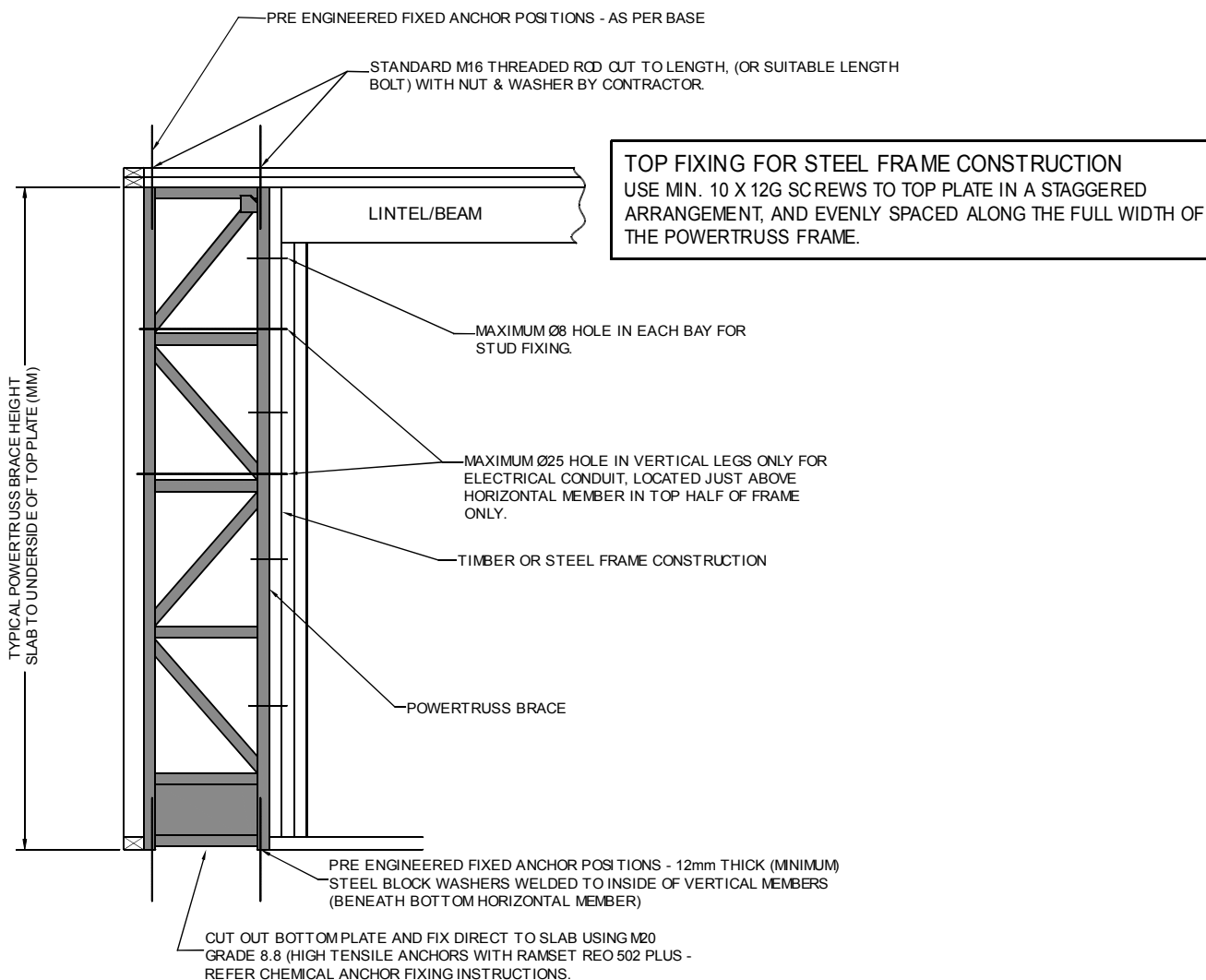

PLEASE ADVISE FINISHED HEIGHT AND WIDTH FOR EACH BRACE REQUIRED

POWERTRUSS WALL BRACING SYSTEM

Queensland (Head Office)

Unit 4-175 Railway Pde
THORNESIDE, QLD. 4158
Phone: (07) 3245 4930
Facsimile: (07) 3245 4838
Email: chris@powertruss.com.au

New South Wales

18-20 Charles Street
ST. MARYS, NSW 2760
Phone: (02) 8646 3366
Email: nsw@powertruss.com.au

Victoria

16 Gaine Road
DANDENONG SOUTH, VIC. 3175
Phone: (03) 9799 9122
Facsimile: (03) 9799 9800
Email: alex@powertruss.com.au