

# POWERTRUSS COLUMN - LATERAL BRACING & LOAD BEARING FRAME INSTALLATION

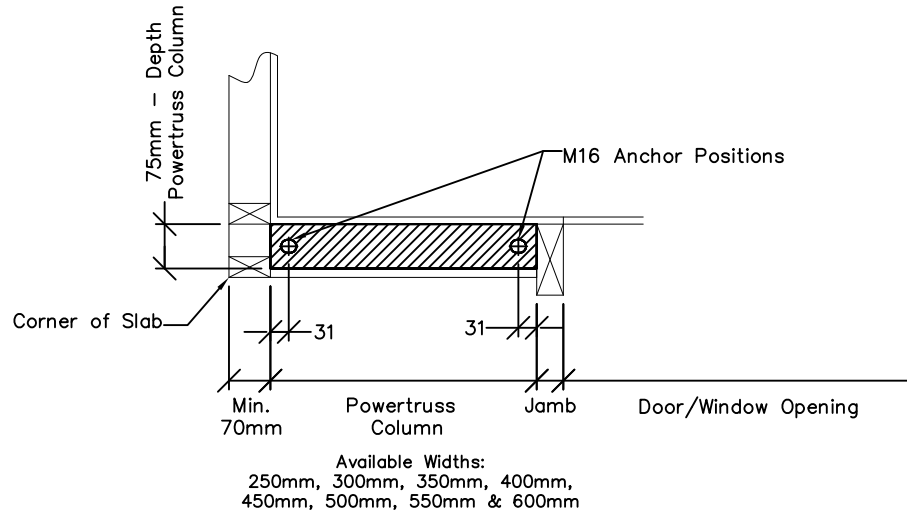

Minimum allowable distance = 70mm from corner of slab to start of Powertruss Frame

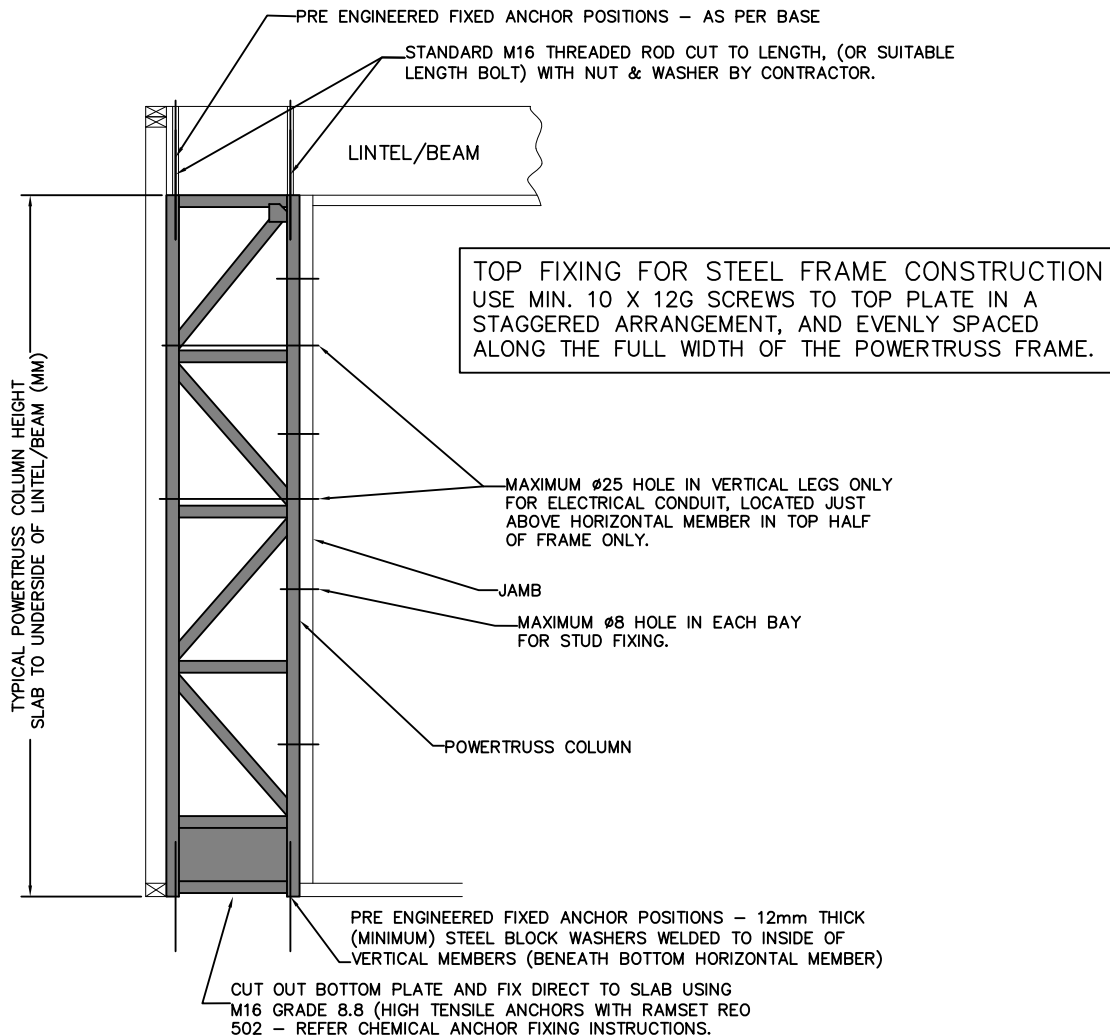

PLEASE ADVISE FINISHED HEIGHT AND WIDTH FOR EACH COLUMN REQUIRED

## POWERTRUSS WALL BRACING SYSTEM

### Queensland (Head Office)

Unit 4-175 Railway Pde  
THORNESIDE, QLD. 4158  
Phone: (07) 3245 4930  
Facsimile: (07) 3245 4838  
Email: neil@powertruss.com.au

### New South Wales

3 Noongah Road  
NELSONS PLAINS, NSW 2324  
Phone: 0410 783 191  
Email: chris@powertruss.com.au

### Victoria

16 Gaine Road  
DANDENONG SOUTH, VIC. 3175  
Phone: (03) 9799 9122  
Facsimile: (03) 9799 9800  
Email: alex@powertruss.com.au